

## SPEC SHEET 280T - 280ML TUB

### PRODUCT DIMENSIONS

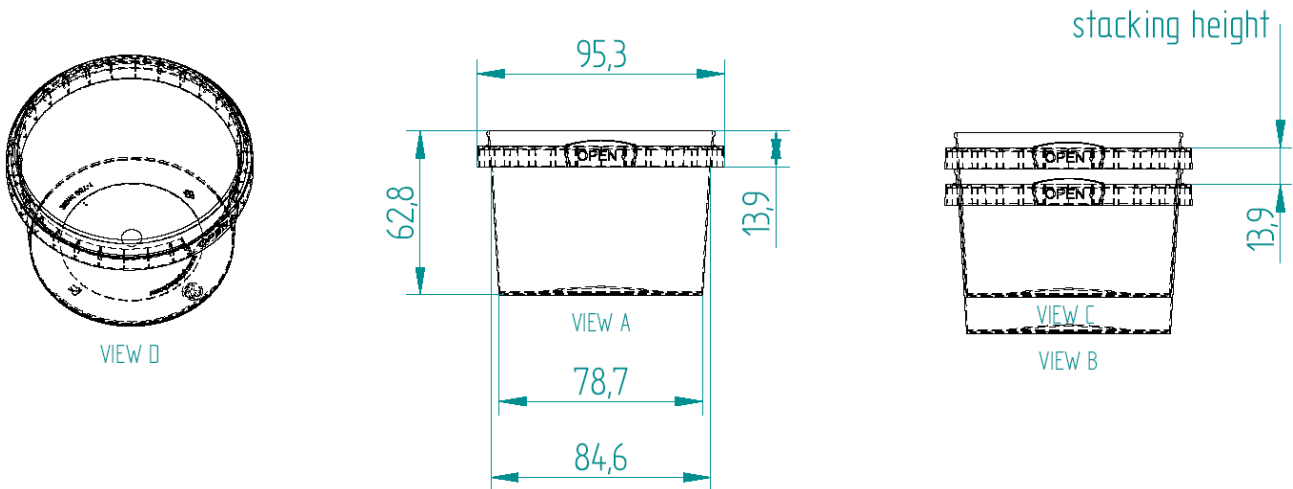

|                 |  |
|-----------------|--|
| TAMPER EVIDENCE | Tamper evidence break-out tab  |
| WEIGHT          | 12.1 g   |
| CAPACITY        | 280 ml   |
| SHAPE           | Round Conical  |
| LID OPTIONS     | L95 Snap On  |
| DECORATION      | In-Mould-Labeling (IML) options are available in various film substrates   |
| MATERIAL        | Polypropylene<br>This product meets the purity limits as stated in AS2070-1999, which relates to plastic materials suitable for food contact applications.   |
| COLOURS         | Natural, Clear, White, Black, Customer specific colours on request   |
| APPLICATION     | <ul style="list-style-type: none"> <li>• Room Temperature / Fridge: standard material</li> <li>• Freezer: special material required</li> <li>• Hot Filling: special material required</li> </ul> <p><b>In all cases, customer should conduct its own trials to ensure the suitability of this packaging for its chosen application</b></p> |
| FEATURES        | Re-heating (may be microwaved), leak resistant, tamper evident   |
| PACKAGING       | <p>QTY per carton: 600</p> <p>Carton size: 620 x 510 x 340 mm</p> <p>Carton liner: HDPE blue plastic liner bag</p> <p>Full carton weight: 8 kg</p> <p>Pallet size: 1165 x 1165 x 2180 mm (max 24 boxes per pallet)</p>   |

