

## SPEC SHEET 565T - 565ML TUB

### PRODUCT DIMENSIONS

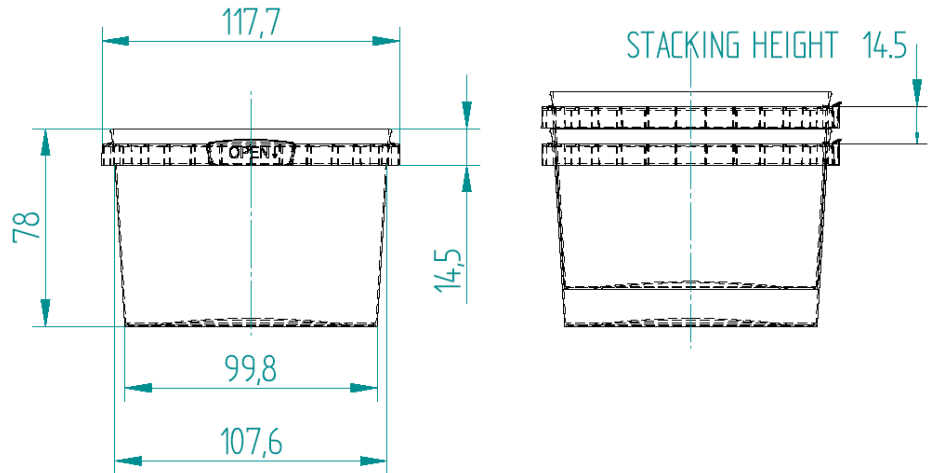
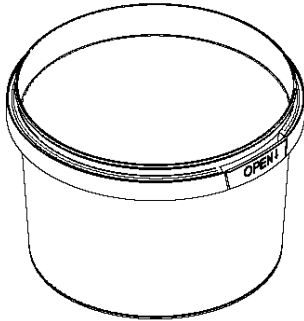

#### TAMPER EVIDENCE

Tamper evidence break-out tab

#### WEIGHT

20.0 g

#### CAPACITY

565 ml

#### SHAPE

Round Conical

#### LID OPTIONS

L118 Snap On

#### DECORATION

In-Mould-Labeling (IML) options are available in various film substrates

#### MATERIAL

Polypropylene

This product meets the purity limits as stated in AS2070-1999, which relates to plastic materials suitable for food contact applications.

#### COLOURS

Natural, Clear, White, Black, Customer specific colours on request

#### APPLICATION

- Room Temperature / Fridge: standard material
- Freezer: special material required
- Hot Filling: special material required

**In all cases, customer should conduct its own trials to ensure the suitability of this packaging for its chosen application**

#### FEATURES

Re-heating (may be microwaved), leak resistant, tamper evident

#### PACKAGING

QTY per carton: 360

Carton size: 620 x 510 x 340 mm

Carton liner: HDPE blue plastic liner bag

Full carton weight: 8 kg

Pallet size: 1165 x 1165 x 2180 mm (max 24 boxes per pallet)

